

Parts Manual

Mfg. No: 1173-0
2,700 PSI

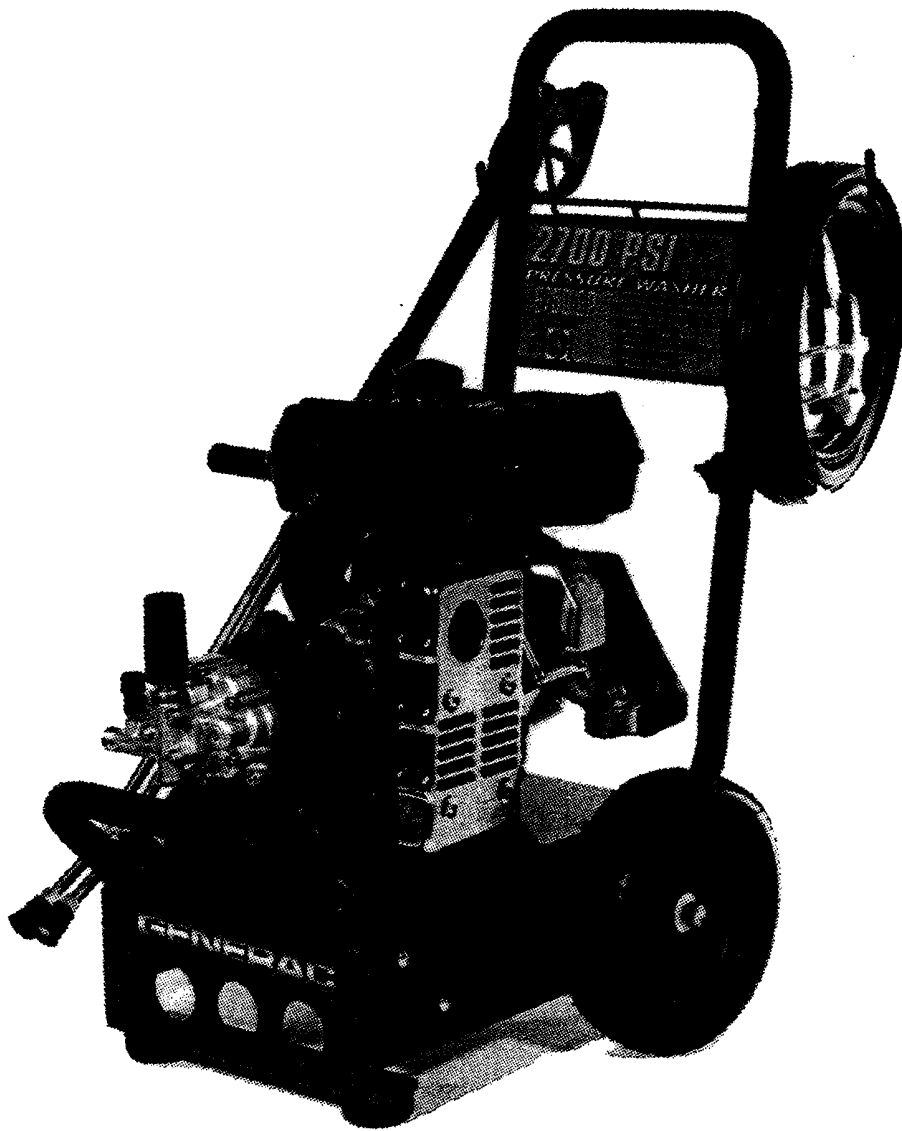

Model Components	Page
Pressure Washer.....	4
Pump.....	8
Torque Specification Chart.....	10

Not For
Reproduction

Pressure Washer

Note: Unless noted otherwise, use the standard torque specifications

Mfg. No: 1173-0

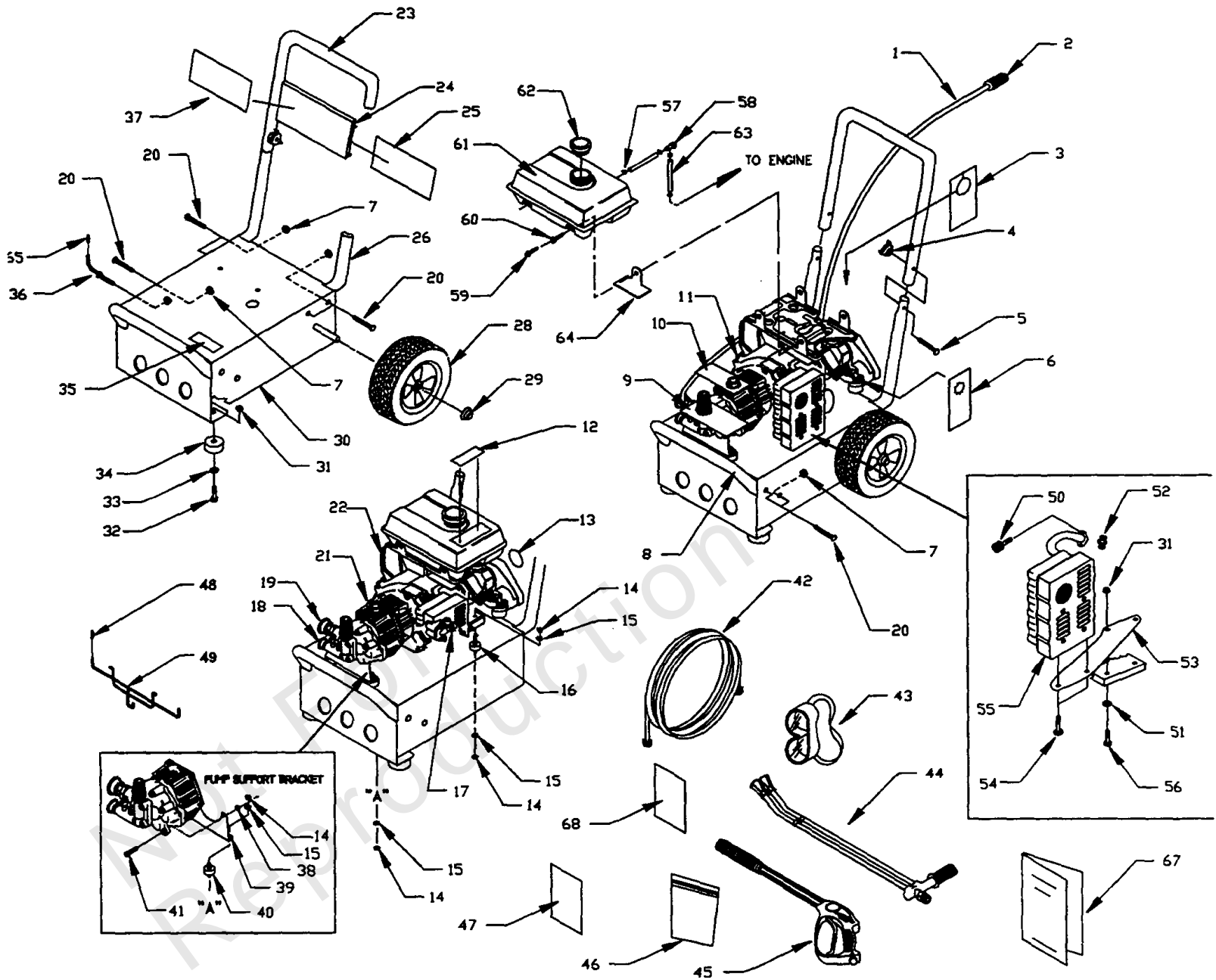

Pressure Washer

REF NO	PART NO	QTY	DESCRIPTION
1	A1043D	1	HOSE, 4-1/2' Chemical Clear
2	A1041	1	FILTER, Chemical Hose
3	94481	1	TAG, Warning Oil -(English/French)
4	97178	2	KNOB, Handle 1/4-20 PW
5	31669	2	BOLT, 1/4-20 x 1-3/4 Carriage
6	B1210B	1	TAG, Start Instructions -(English/French)
7	99583	8	NUT, Range Lock 5/16-18
8	B1982	1	BUMPER
9	98944	1	TAG, Pres. Adjust -(English/French)
10	B1288	1	TAG, PW Breather Cap, -(Tri-Lingual)
11	B1232	1	CLAMP, Hose 7/16" Dia.
12	96686	1	DECAL, Danger -(French)
13	91682B	1	DECAL, Recoil
14	45771	7	NUT, M8-1.25 Hex
15	22129	7	LOCKWASHER, M8
16	21217	2	MOUNT, Rubber Shock
17	74031	.001	QT., Liquid Neoprene
18	97100	1	CAP, H.P. Adaptor
19	97098	1	CAP, Garden Hose Inlet
20	B2043	7	BOLT, 5/16-18 x 1-3/4 Carriage
21	----	1	ASSEMBLY, Pump -(see pump exploded view)
22	ENGB2219	1	ENGINE
23	B1983	1	HANDLE
24	B1631A	1	BILLBOARD, Plastic
25	B2772	1	DECAL Instructions
26	B1981	2	SUPPORT, Handle
27	B2192	1	DECAL Generac
28	B1760	2	ASSEMBLY, 10" Tire & Wheel
29	75402	2	PUSHNUT, .50 Dia.
30	AB1770	1	BASE
31	52858	3	NUT, M8 1.25 Locking
32	42909	2	HHCS, M8 1.25 x 30
33	50190	2	WASHER, M8 FFlat
34	27007	2	MOUNT, Donut Type Vibration
35	20566	1	DECAL, Generac #1-800
36	B2150	1	HOOK, Gun
37	B1990	1	DECAL, Logo
38	52857	2	NUT, M6 1.0 Locking
39	20707	1	BRACKET, Pump Support
40	21216	2	MOUNT, Rubber Shock
41	38750	2	HHCS, M6 1.0 x 30
42	91630	1	HOSE, High Pressure
43	87815	1	GOGGLES,
44	B2140C	1	LANCE, Dual
45	B1862	1	GUN, High Pressure
46	B2203	1	KIT, Handle Fastening
47	B2508	1	KIT, Cleaning

Pressure Washer

Note: Unless noted otherwise, use the standard torque specifications

Mfg. No: 1173-0

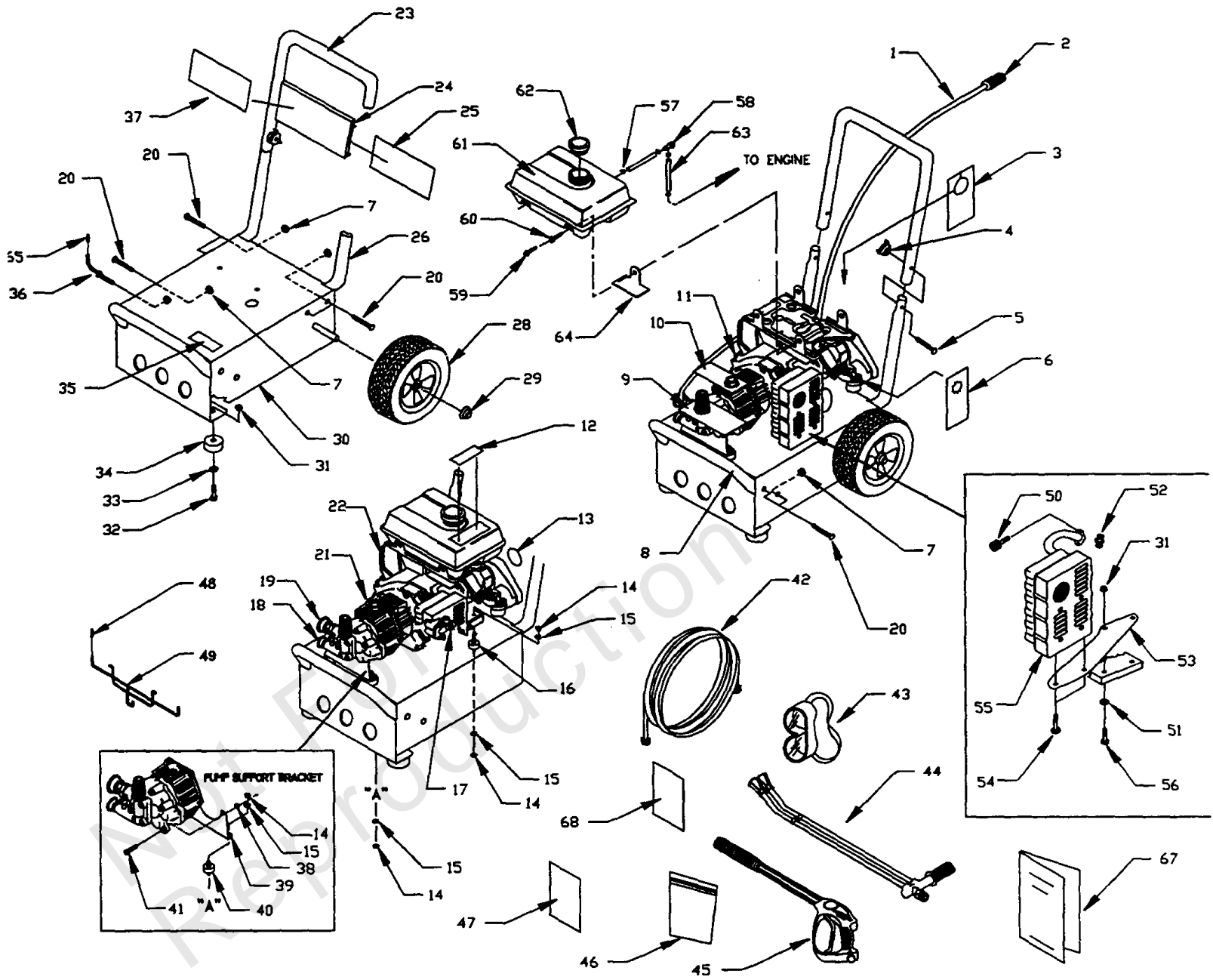

Pressure Washer

REF NO	PART NO	QTY	DESCRIPTION
48	B1460	2	CAP, Vinyl -(black)
49	B2168	1	HANGER, Hose, Gun, Jug
50	40976	2	SHCS, M8 1.25 x 20
51	-----	1	WASHER, Flat, 5/16
52	89476	1	GASKET, Exhaust
53	83208	1	BRACKET, Muffler
54	66476	2	HHCS, M6 1.0 x 12
55	83071	1	MUFFLER
56	39414	1	HHCS, M8 - 1.25 x 35
57	48031C	3	CLAMP, Hose
58	96193	1	VALVE, Fuel Shut Off
59	96001	4	BOLT, M6 - 1.0 x 21 Lg. Shoulder
60	96002	4	BUSHING, Tank
61	94994	1	TANK, 1 Gal Fuel
62	95549	1	CAP, Fuel
63	30340	1	HOSE, Fuel-1/4" I.D.
64	21545	1	SHIELD, Heat
65	B2516	1	CAP, Vinyl -(black)
66	67989	1	NUT, M8 Flange Serrated
67	B2779	1	MANUAL -(English/French)
68	B3064	1	SHEET, Nozzle Cleaning -(French)

Pump

Note: Unless noted otherwise, use the standard torque specifications

Mfg. No: 1173-0

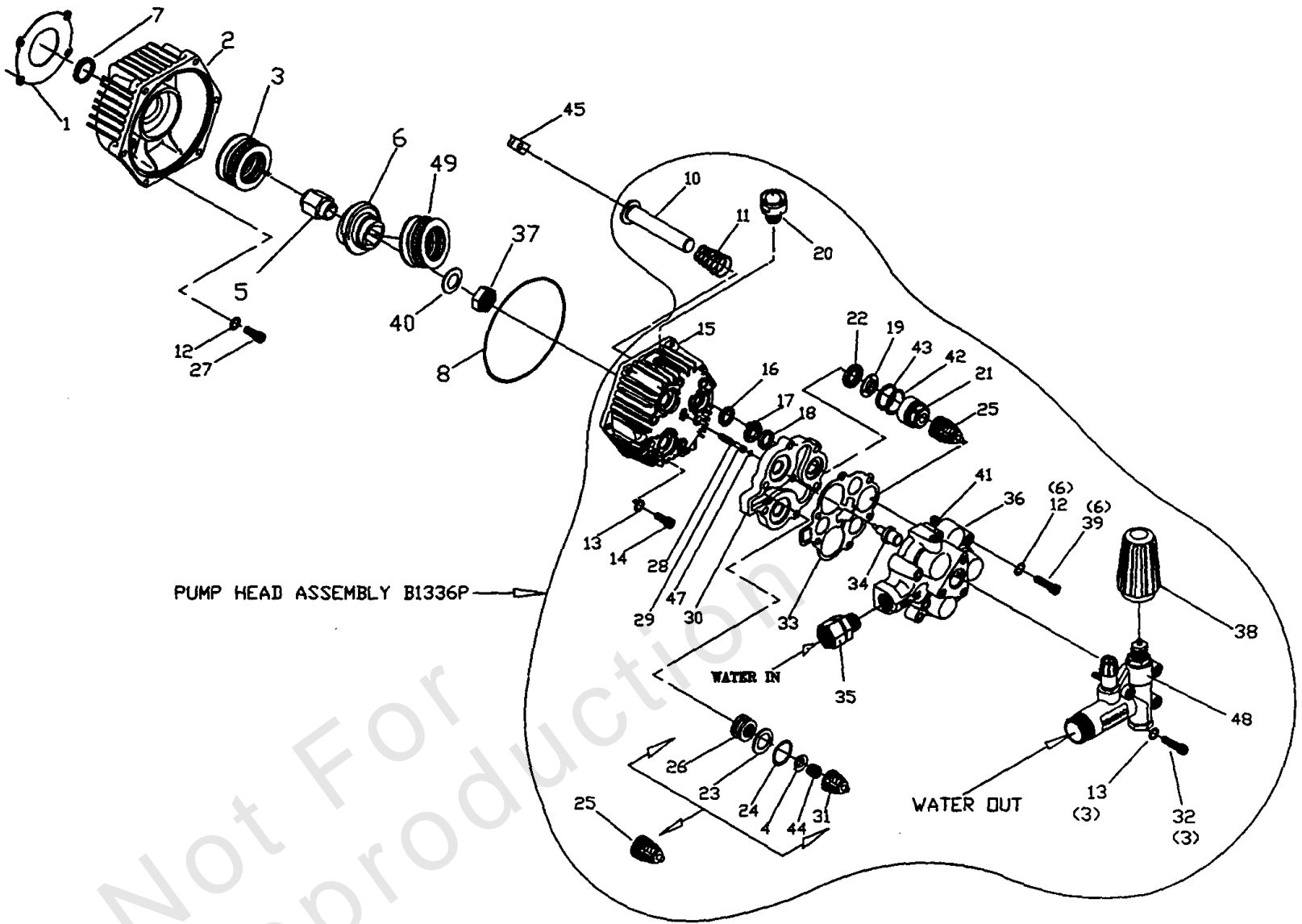

Pump

REF NO	PART NO	QTY	DESCRIPTION
1	93871	1	GASKET, ENGINE ADAPTOR
2	96430A	1	ADAPTOR, ENGINE
3	96542	1	BEARING, ROLLER THRUST
4	97215	6	POPPET, CHECK VALVE
5	96165	1	ADAPT., ENG SHAFT
6	21277V	1	AXIAL CAM
7	95441	1	SLEEVE, ENG, ADAPTOR
8	93790	1	"O" RING
10	99427	3	PISTON
11	96400	3	SPRING, PISTON RETURN
12	92479	10	LOCKWASHER, M8-RIBBED
13	93873	9	LOCKWASHER, M6-RIBBED
14	40945	9	M6 x 1 x 20 LONG SHCS.
15	97568A	1	CRANKCASE, ALUMINUM
16	93680	3	SEAL, OIL-PISTON
17	93668	3	SPACER, PILOT
18	93667	3	SEAL, LO-PRES "U" PAK
19	96015	3	RING, BEARING SEAL
20	99735	1	CAP, BREATHER
21	97027	3	TOWER, HIGH PRESS. PORT
22	96053	3	SEAL, HIGH PRESS. - BLACK
23	95504	6	RING, BACK-UP
24	95503	6	"O" RING
25	97128	6	KIT, CHECK VALVE
26	97028	6	SUPPORT, CHECK VALVE, PLASTIC
27	23707	4	BOLT, 5/16-24 x 1' SHC
28	93652	1	SPRING, THERMAL BY-PASS
29	95416	1	PISTON, BY-PASS
30	97122P	1	PLATE, SPACER
31	89137	6	GUIDE, CHECK VALVE PLASTIC
32	46580	3	M6-1 x 45 SHCS
33	93645	1	GASKET, HEAD
34	93644	1	ACTUATOR, THERMAL BY-PASS
35	95320	1	CONNECTOR, GARDEN HOSE
36	95138	1	HEAD, CYLINDER
37	93887	1	NUT, JAM.
38	B1339	0	HANDLE -(Replacement Part Only)
39	93874	6	SHCS, M8-1.25 x 75
40	94738	1	WASHER, BELLEVILLE
41	96137	1	Plug, Pipe 1/8 NPT
42	96069	3	"O" RING
43	95506	3	RING, BACK-UP
44	89138	6	SPRING, CHECK VALVE
45	94944	3	SHOE, PISTON PIVOT
47	93876	1	"O"-RING
48	21746	1	ASSEMBLY, UNLOADER
49	97606	1	BEARING ASSEMBLY

Hardware Identification & Torque Specifications

Torque Specification Chart								
FOR STANDARD METRIC MACHINE HARDWARE (Tolerance ± 20%)								
Property Class	5.6		8.8		10.9		12.9	
	Class 5.6		Class 8.8		Class 10.9		Class 12.9	
Size Of Hardware	in/lbs	Nm.	in/lbs	Nm.	in/lbs	Nm.	in/lbs	Nm.
	ft/lbs		ft/lbs		ft/lbs		ft/lbs	
M3	5.88	.56	13.44	1.28	19.2	1.80	22.92	2.15
M4	13.44	1.28	30.72	2.90	43.44	4.10	52.56	4.95
M5	26.4	2.50	60.96	5.75	5.97	8.10	7.15	9.7
M6	44.64	4.3	7.3	9.9	10.3	14	12.1	16.5
M7	5.2	7.1	12.1	16.5	16.9	23	19.9	27
M8	7.7	10.5	17.7	24	25	34	29	40
M10	15	21	35	48	50	67	59	81
M12	26	36	61	83	86.2	117	103	140
M14	42	58	101	132	136	185	162	220
M16	64	88	147	200	210	285	250	340
M18	89	121	202	275	287	390	346	470
M20	126	171	290	390	405	550	486	660
M22	169	230	390	530	559	745	656	890
M24	217	295	497	375	708	960	840	1140
M27	320	435	733	995	1032	1400	1239	1680
M30	435	590	995	1350	1401	1900	1681	2280
M33	590	800	1349	1830	1902	2580	2278	3090
M36	759	1030	1740	2360	2441	3310	2935	3980
M39	988	1340	2249	3050	3163	4290	3798	5150

Torque Specification Chart						
FOR STANDARD MACHINE HARDWARE (Tolerance ± 20%)						
Hardware Grade	No Marks		SAE Grade 5		SAE Grade 8	
	SAE Grade 2		SAE Grade 5		SAE Grade 8	
Size Of Hardware	in/lbs	Nm.	in/lbs	Nm.	in/lbs	Nm.
	ft/lbs		ft/lbs		ft/lbs	
8-32	19	2.1	30	3.4	41	4.6
8-36	20	2.3	31	3.5	43	4.9
10-24	27	3.1	43	4.9	60	6.8
10-32	31	3.5	49	5.5	68	7.7
1/4-20	66	7.6	8	10.9	12	16.3
1/4-28	76	8.6	10	13.6	14	19.0
5/16-18	11	15.0	17	23.1	25	34.0
5/16-24	12	16.3	19	25.8	29	34.0
3/8-16	20	27.2	30	40.8	45	61.2
3/8-24	23	31.3	35	47.6	50	68.0
7/16-14	30	40.8	50	68.0	70	95.2
7/16-20	35	47.6	55	74.8	80	108.8
1/2-13	50	68.0	75	102.0	110	149.6
1/2-20	55	74.8	90	122.4	120	163.2
9/16-12	65	88.4	110	149.6	150	204.0
9/16-18	75	102.0	120	163.2	170	231.2
5/8-11	90	122.4	150	204.0	220	299.2
5/8-18	100	136	180	244.8	240	326.4
3/4-10	160	217.6	260	353.6	386	525.0
3/4-16	180	244.8	300	408.0	420	571.2
7/8-9	140	190.4	400	544.0	600	816.0
7/8-14	155	210.8	440	598.4	660	897.6
1-8	220	299.2	580	788.8	900	1,244.0
1-12	240	326.4	640	870.4	1,000	1,360.0

The guides and ruler furnished below are designed to help you select the appropriate hardware.

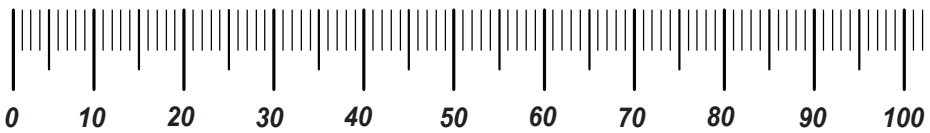

Nut, M8

Thread Diameter (mm)

Inside Diameter (in) Threads per inch

Nut, 1/2-16

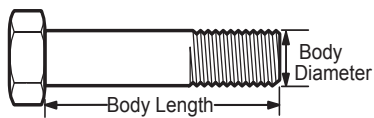

Screw, M8- 1.25 x 25

Thread Diameter (mm) Distance between threads (mm) Body Length (mm)

Body Diameter Threads per inch Body Length (in)

Screw, 1/2- 16 x 2



Standard Hardware Sizing

When a washer or nut is identified as 1/2" (M8), this is the *Nominal size*, meaning the *inside diameter* is 1/2 inch (8mm metric thread diameter); if a second number is present it represents the *threads per inch* (distance between threads).

When bolt or capscrew is identified as 1/2 - 16 x 2" (M8 - 1.25 x 50), this means the *Nominal size*, or body diameter is 1/2 inch (8mm metric thread diameter), the second number, 16, represents the *threads per inch*, (*distance between threads*). The final number is the body length of the bolt or screw, 2 inches (50mm).

NOTES

- These torque values are to be used for all hardware excluding: locknuts, self-tapping screws, thread forming screws, sheet metal screws and socket head setscrews.
- Recommended seating torque values for locknuts:
 - for prevailing torque locknuts - use 65% of grade 5 torques.
 - for flange whizlock nuts and screws - use 135% of grade 5 torques.
- Unless otherwise noted on assembly drawings, all torque values must meet this specification.

Common Hardware Types

Hex Head Capscrew

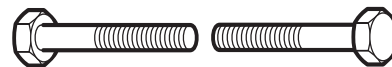

Washer



Carriage Bolt



Hex Nut

Wrench & Fastener Size Guide

1/4" Bolt or Nut Wrench—7/16"	5/16" Bolt or Nut Wrench—1/2"	3/8" Bolt or Nut Wrench—9/16"	7/16" Bolt or Nut Wrench (Bolt)—5/8" Wrench (Nut)—11/16"	1/2" Bolt or Nut Wrench—3/4"
M6 Bolt or Nut Wrench—10mm	M8 Bolt or Nut Wrench—13mm	M10 Bolt or Nut Wrench—17mm	M12 Bolt or Nut Wrench—19mm	M14 Bolt or Nut Wrench—22mm

